



In-Flight Anomalies and Radiation Performance of NASA Missions - *Selected Lessons Learned*

Kenneth A. LaBel
Co- Manager, NASA Electronic Parts and Packaging (NEPP) Program
Group Leader, Radiation Effects and Analysis Group (REAG)
NASA/GSFC
ken.label@nasa.gov
301-286-9936
<http://nepp.nasa.gov>



Outline of Presentation

- Investigative Approach
- An Optocoupler's Tale
- On the Matter of Small Probabilities
- What's with the Noise Spikes?
- The Meaning of an Upset in a Fiber Optic Link
- Considerations

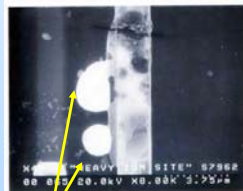

*Latent damage sites: device did not fail during ground irradiation,
but at some time afterward during operation.*

Could this have been observed in-flight?

In-Flight Electronics and Radiation – Presented by Kenneth A. LaBel, SERESSA, West Palm Beach, FL 12/2/2008

2



Anomaly Resolution – *Root Cause Investigation for Radiation Engineers*

- Determine orbital location and time of event
 - Look for the obvious such as solar events or South Atlantic Anomaly (SAA)
- Review electronic parts list for potential sensitive devices
- Review identified device in specific circuit application
 - Factors such as duty cycle, operating speed, voltage levels, and so forth
- Obtain existing SEE, dose, and damage data or gather new data
 - Compare applications between in-circuit and ground data
 - Perform ground testing if needed
- Determine **risk probabilities**
 - SEE rates, etc
 - Failure potential
- Recommend mitigative action(s) of possible

In-Flight Electronics and Radiation – Presented by Kenneth A. LaBel, SERESSA, West Palm Beach, FL 12/2/2008

3



An Optocoupler's Tale - Background

- Optocouplers
 - Used extensively for the isolation of signals between systems or boxes
 - Translate electrical signals to optical, then back to electrical
- What radiation-induced failure modes may exist?
 - Long-term degradation such as current transfer ratio (CTR) – output/input
 - Single particle events
 - Photodiodes, for example, have a history of being used as energetic particle detectors!



Typical Block Diagram of an Optocoupler

In-Flight Electronics and Radiation – Presented by Kenneth A. LaBel, SERESSA, West Palm Beach, FL 12/2/2008

4

An Optocoupler's Tale – NASA's Most Famous Science Spacecraft



- Hubble Space Telescope (HST)
 - Flying for over 18 years
 - Tremendous scientific discoveries (as well as gorgeous images!)
- HST has had several servicing missions (SM)
 - New instruments
 - System upgrades and maintenance
- On the SM2, launched Feb 14th, 1997, two new instruments were installed
 - Multiple anomalies were observed during the on-orbit engineering calibration for these instruments
 - HST's main radiation concern is SAA



In-Flight Electronics and Radiation – Presented by Kenneth A. LaBel, SERESSA, West Palm Beach, FL 12/2/2008

5

An Optocoupler's Tale – Resolving the Anomaly



- What steps were needed to determine **ROOT CAUSE** and action?
 - Review of environment during anomalies
 - All events occurred in the SAA
 - Review of parts list
 - Optocoupler highlighted as most likely candidate
 - Review of circuit application
 - SETs simulated showing possible cause
 - SET could trigger a high-voltage portion of the instrument and cause failure
 - Review or gather radiation test data
 - No data existed; accelerator test performed

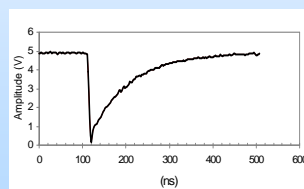

**Typical Measured Transient
During Proton Irradiation**

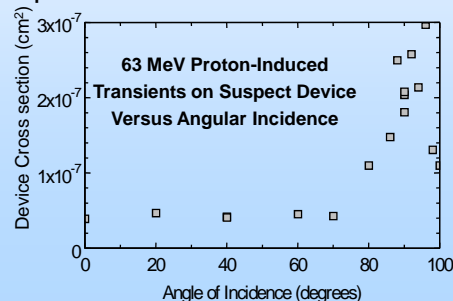

In-Flight Electronics and Radiation – Presented by Kenneth A. LaBel, SERESSA, West Palm Beach, FL 12/2/2008

6

The Optocoupler – Final Analysis



- What steps were needed to determine ROOT CAUSE and action? - continued
 - Determine risk probability (i.e., upset rates)
 - Optocouplers are not just electrical
 - Considerations for tools beyond CREME96 began with this and related work
 - Determine actions to mitigate or reduce risk
 - In-flight hardware is not easily modified ;o(
 - FPGAs improve this ability (but not here)
 - Operational change installed via software update
 - No instrument operation during SAA
 - Critical science was **NOT** impacted, but some science data loss incurred

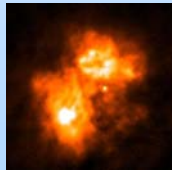

In-Flight Electronics and Radiation – Presented by Kenneth A. LaBel, SERESSA, West Palm Beach, FL 12/2/2008

7

On the Matter of Small Probabilities - Background



- Solid State Recorders (SSRs)
 - A means storing science data on-board a spacecraft
 - Use high-density memory ICs for density/power advantages
 - SRAM (early 1990's)
 - DRAM (mid-1990's and later)
 - Flash (being considered)
- DRAMs: What radiation-induced failure modes may exist?
 - TID
 - Traditional leakage increases, cell failures, etc...
 - SEE
 - Destructive: SEL, stuck bits
 - Upset: bit/multiple bits, block errors, mode errors, SEFI

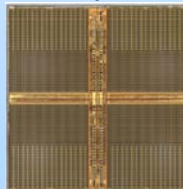

1 Gb SDRAM circa 2006
Feature size is 90nm

In-Flight Electronics and Radiation – Presented by Kenneth A. LaBel, SERESSA, West Palm Beach, FL 12/2/2008

8

On the Matter of Small Probabilities – NASA's Most Famous Science Spacecraft (yet again!)



- On the SM2, Feb 14th, 1997, a new SSR was installed to increase data storage capacity
 - HST passes through the SAA several times daily
 - Bit upsets tracked fairly well with predicted rate based on ground data (3 samples, one proton energy)
 - **HOWEVER**, two more complex anomalies were observed
 - Each had ~ 100 bits in error (block)
 - Block was not corrected by a re-write
 - **Project in panic!**

HST SSR utilizes
Irvine Sensors DRAM Modules
Comprised of 16 Mb IBM Luna DRAMs

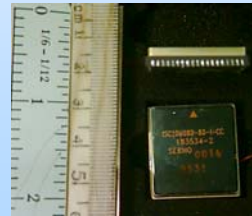

In-Flight Electronics and Radiation – Presented by Kenneth A. LaBel, SERESSA, West Palm Beach, FL 12/2/2008

9

On the Matter of Small Probabilities– Resolving the Anomaly



- What steps were needed to determine ROOT CAUSE and action?
 - Review of environment during anomaly
 - SAA
 - Review of parts list
 - Memory controller was rad-hard
 - DRAM was not
 - Review of circuit application
 - Circuit application was the same as in ground testing (refresh rate, etc)
 - Review or gather radiation test data
 - Proton data: no observed block errors (**sample size = 3 w/ 1x environment fluences**)
 - **HOWEVER**, heavy ion data exhibited these type of events at low LETs
 - Proton events would be expected
 - New test data required for statistics on 1440 device usage
 - **With 1440 devices being used for this SSR application**
 - **Expected event cross-section of ~a few E-13 cm² based on 2 events in 9 months versus (predicted) in-flight proton fluence**

In-Flight Electronics and Radiation – Presented by Kenneth A. LaBel, SERESSA, West Palm Beach, FL 12/2/2008

10

On the Matter of Small Probabilities— Final Analysis



- Review or gather radiation test data (cont'd)
 - New test undertaken with protons with 100 die and to higher proton fluence levels
 - 9 events observed during $1.5E11$ p/cm² fluence (~100x over expected HST fluence levels)
 - 2 different event signatures noted
 - » block (column/row) errors
 - » weak columns (suspect data – sometimes good, sometimes bad)
- Determine risk probability (i.e., upset rates)
 - Predicted error rate of 2.2/yr is the **same** order of magnitude as observed
- Determine actions to mitigate or reduce risk
 - Reset of mode register or power cycle clear the anomaly
 - Circuitry not included to provide reset
 - Power cycle determined to be feasible when needed
 - Data is Reed-Solomon (RS) Encoded
 - » Probability of RS failure is low
 - No action taken at that time



In-Flight Electronics and Radiation – Presented by Kenneth A. LaBel, SERESSA, West Palm Beach, FL 12/2/2008

11

What's With the Noise Spike? - Background



- Linear devices such as analog comparators are
 - Used extensively in instruments, power, data collection, and more
 - Compares the voltage levels between two analog signals
- What radiation-induced failure modes may exist?
 - Long-term degradation is focused on
 - Enhanced low dose rate sensitivity (ELDRS) and displacement damage (in bipolars)
 - Single events
 - Single event transients (SETs) have been the prime concern.

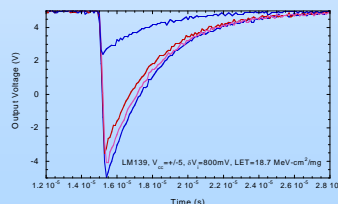

Sample SETs induced by heavy ions
in a PM/LM139 comparator

In-Flight Electronics and Radiation – Presented by Kenneth A. LaBel, SERESSA, West Palm Beach, FL 12/2/2008

12

What's With the Noise Spike? – Microwave Anisotropy Probe (MAP)



- Launched June 30, 2001.
 - Had phasing orbits prior to insertion in final orbit.
- Reached its final orbital position on L2 end of September, 2001.
- An anomaly occurred causing a reset of the spacecraft processor on November 5, 2001.

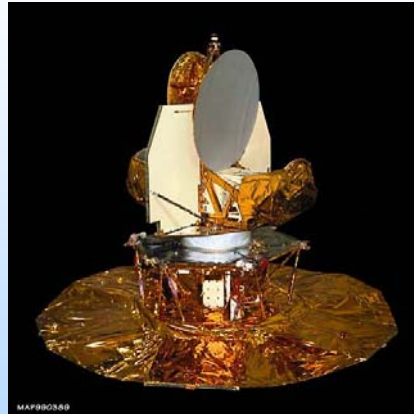

In-Flight Electronics and Radiation – Presented by Kenneth A. LaBel, SERESSA, West Palm Beach, FL 12/2/2008

13

What's With the Noise Spike? – Resolving the Anomaly



- What steps were needed to determine ROOT CAUSE and action?
 - Review of environment during anomaly
 - Solar event
 - *Significant heavy ion component*
 - Review of parts list
 - Analog comparator (PM/LM139) identified as likely problem

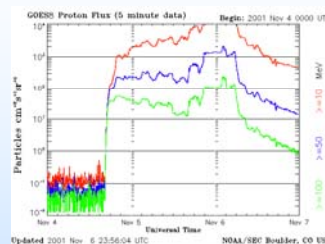

Data from NOAA/SEC/SWO

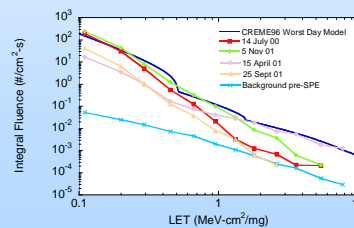

after Dyer, 2002

In-Flight Electronics and Radiation – Presented by Kenneth A. LaBel, SERESSA, West Palm Beach, FL 12/2/2008

14

What's With the Noise Spike? – Resolving the Anomaly (2)



- Review of circuit application
 - Confirmed that LM/PM139 could be the cause
 - Application had changed since initial parts review pre-launch
- Review or gather radiation test data
 - **No** documented proton sensitivity
 - Heavy ion sensitivity documented as a function of the application using existing data plus new data gathered

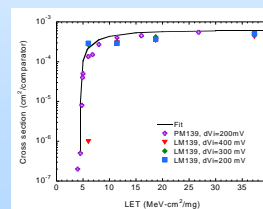
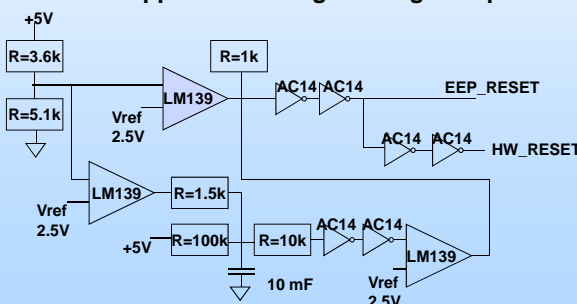

Heavy ion data

In-Flight Electronics and Radiation – Presented by Kenneth A. LaBel, SERESSA, West Palm Beach, FL 12/2/2008

15

What's With the Noise Spike? – Final Analysis



- What steps were needed to determine ROOT CAUSE and action?
 - continued
 - Determine risk probability (i.e., upset rates with heavy ions)
 - Additional shielding analysis performed for particle transport
 - Assumption of sensitive volume thicknesses
 - Determine actions to mitigate or reduce risk
 - Event rates deemed acceptable by project
 - No action taken

Sensitive volume thickness (μm)	GCR SET rate CREME96, solar maximum (event/ comparator-day)	Solar Event CREME96, worst day (event/ comparator-day)
10	1.8E-3	5.1E-1
15	1.7E-3	3.0E-1
20	1.6E-3	1.8E-1
30	1.5E-3	6.5E-2
40	1.3E-3	4.4E-2
60	9.9E-4	3.4E-2

In-Flight Electronics and Radiation – Presented by Kenneth A. LaBel, SERESSA, West Palm Beach, FL 12/2/2008

16

The Meaning of an Upset in a Fiber Optic Link (FOL) - Background



- FOLs
 - MIL-STD-1773 implementation (1 MHz) used since the early 1990's in many NASA systems
 - Transmits electrical data and command signals to/from optical
- What radiation-induced failure modes may exist?
 - Similar to optocouplers
 - SEUs imply single or multi-bit errors
 - Photodiodes, have a history of being used as energetic particle detectors.
 - Errors are temporal via photodiode
 - Transients may affect more than one clock cycle
 - High-speed electrical circuits also sensitive
 - Major impact is on data *bit error rate* (BER)

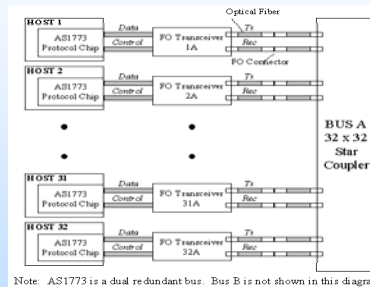

Note: ASI1773 is a dual redundant bus. Bus B is not shown in this diagram

Representative FOL architecture

The Meaning of an Upset in a Fiber Optic Link (FOL)- Background (cont'd)



- Original MIL-STD-1773 transceivers used Si photodiodes
 - Sensitive to direct ionization from protons
 - Implies high bit error rate (BER) for space applications.
 - Angle of incidence, optical power budget, and proton energy effects noted
- This forced the usage of protocol fault-tolerant features to be implemented (**message retries**).
 - Used successfully in NASA missions
 - **BUT** reduced effective bus bandwidth by ~50%.
 - For higher data rate systems, this hardening solution may not be applicable.

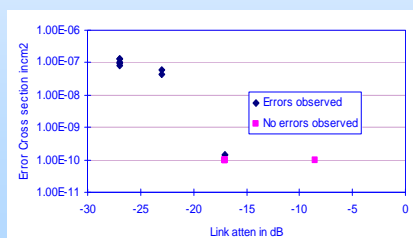

Ground data illustrating the effect of optical power budget on radiation performance

The Meaning of an Upset in a Fiber Optic Link (FOL)- Making a Better Mousetrap



- Hardening methodologies explored
 - Change of optical wavelength from 850 nm to 1300 nm light showed improved SEU tolerance
 - Reduced volume of photodiode
 - Receiver noise filtering techniques and optical power budgets also help
 - Higher data rate development (20 MHz) – AS1773
 - *Flown as an experiment on Microelectronics and Photonics Testbed (MPTB)*
 - Boeing DR1773 Transceivers

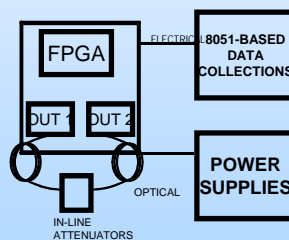

MPTB DR1773 Test Board

In-Flight Electronics and Radiation – Presented by Kenneth A. LaBel, SERESSA, West Palm Beach, FL 12/2/2008

19

The Meaning of an Upset in a Fiber Optic Link (FOL) – MPTB Performance



- MPTB launched in 1997
 - 6 years of in-flight performance in a **highly elliptical orbit (HEO)**
- Transceivers were operated in two modes
 - ED mode used a physical contact (PC) polished fiber optic terminal
 - DE mode used a flat polished connector (air gap)
 - *Which do you think would work better?*

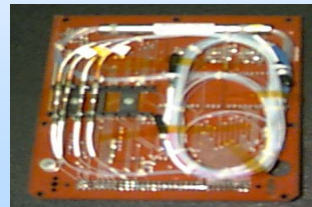
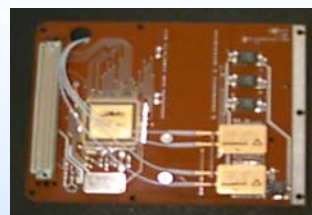

In-Flight Electronics and Radiation – Presented by Kenneth A. LaBel, SERESSA, West Palm Beach, FL 12/2/2008

20

The Meaning of an Upset in a Fiber Optic Link (FOL) – In-Flight



- Did the hardening effort pay off?

ED and DE bit error rates by Year

Year	ED BER	DE BER
1997	1.738E ⁻¹²	N/A
1998	4.224E ⁻¹⁴	3.787E ⁻¹¹
1999	3.855E ⁻¹⁴	5.303E ⁻¹¹
2000	0	8.501E ⁻¹¹
2001	8.168E ⁻¹⁵	N/A
2002	0	N/A

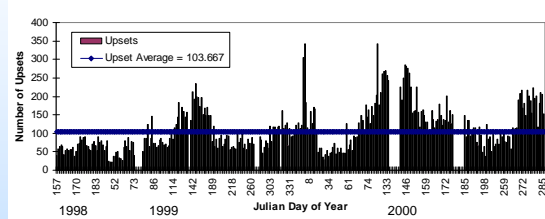

MPTB Transceiver DE Mode 1998-2000 Orbits 0036-3111

Physical contact

Air Gap

Few errors were noted on the “good” PC

Considerations



- Methodical process for anomaly review takes into account
 - Environment
 - Selected parts
 - Design
 - Existing radiation test data and/or new data
 - Impact (i.e., risk probability)
 - Actions (mitigative or otherwise)
- Notes:
 - Design and parts list reviews are good for flight programs
 - **BUT**, any changes later in design process need to be reviewed as well
 - Protons aren't always the cause of anomalies during solar events
 - Solar heavy ions must be taken into account
 - System design and not just device radiation tolerance needs to be taken into account
 - Mechanical issues, for example, can be related (as in the FOL example)
 - Spacecraft charging effects not discussed, but should be considered as well
 - *Can charging in plastic packages be the next SEU?*