

SEE Test Report V2.0  
 Heavy ion SEE test of SMTR283R3S from Interpoint  
 Anthony B. Sanders<sup>1</sup>, Hak S. Kim<sup>2</sup>, Anthony M. Phan<sup>2</sup>

<sup>1</sup> NASA GSFC  
<sup>2</sup> MEI Technologies

Test Date(s): March 2-6, 2010

## I. Introduction

This study was undertaken to determine the single event destructive and transient susceptibility of the SMTR283R3S, Single DC/DC Converters, for transient interruptions in the output signal and for destructive events induced by exposing it to a heavy ion beam at the Radiation Effects Facility at The Cyclotron Institute located on the campus of Texas A&M University. This test was performed for the investigation of radiation susceptibility of transient events and destructive events for Crane Interpoint. This work was in conjunction with the NASA Electronics Parts and Packaging (NEPP) Program. NEPP is a HQ sponsored program that seeks to find new developments that will benefit NASA.

## II. Devices Tested

The sample size of Device Under Test (DUT) for testing was three. Each device was exposed to the radiation beam and the results were compared for verification. For the SMTR283R3S, the test samples code markings for DUT1 is SN-0423, DC-0408; DUT2 SN-0722, DC-0972; & DUT3 SN-0711, DC-0733. The device is packaged in a 10-pin lead metal can package. The device was prepped for test by delidding. The SMTR series of 28V DC/DC converters offers up to 30 watts of output power from single, dual or triple output configurations. They converters operate over the full military temperature range of -55C to +125C with up to 84% efficiency (up to 73% efficiency triple models). SMTR converters are packaged in hermetically sealed metal enclosures, making them ideal for use in military, aerospace and other high reliability applications.

The SMTR converters are constant frequency, pulse-width modulated switching regulators that use a quasi-square wave, single ended, forward design. Tight load regulation is maintained by using a wide bandwidth magnetic feedback and on single output models, through use of remote sense. On dual output models, the positive output is independently regulated and the negative output is cross regulated through the use of tightly-coupled magnetics. The design of the triple series includes individual regulators on the auxiliary outputs which provide for no cross regulation error when a minimum 300 mA load is maintained on the main (+5) output.

## III. Test Facility

**Facility:** Texas A&M Cyclotron Radiation Effects Facility, 15 MeV/u beams

**Flux:**  $5.72 \times 10^2$  to  $3.99 \times 10^4$  particles/cm<sup>2</sup>/s.

**Fuence:** For destructive events, all tests were ran to  $1 \times 10^6$  p/cm<sup>2</sup> or until destructive events occurred

For non destructive events, all tests were ran to  $1 \times 10^6$  p/cm<sup>2</sup> or until a sufficient (>100) number of transient events occurred.

The ions and LET values used for these tests were Xe & Ta.

#### IV. Test Conditions and Error Modes

**Test Temperature:** Room Temperature  
**Bias conditions**  $V_{in} = 28V$ ,  $V_{out} = 3.3V$   
 See Figure 2 for detailed conditions

	<b>Vsupply (V)</b>	<b>Isupply (mA)</b>	<b>Vin (V)</b>	<b>Loading %</b>
DUT 1	+3.3V	28	28V	0
DUT 1	+3.3V	500	28V	30
DUT 1	+3.3V	649	21V	30
DUT 1	+3.3V	415	35V	30
DUT 2	+3.3V	30	28V	0
DUT 2	+3.3V	495	28V	30
DUT 2	+3.3V	633	21V	30
DUT 2	+3.3V	369	35V	30
DUT 3	+3.3V	29	28V	0
DUT 3	+3.3V	512	28V	30
DUT 3	+3.3V	658	21V	30
DUT 3	+3.3V	422	35V	30

Table 1: Test conditions

**PARAMETERS OF INTEREST:** Power supply currents, output voltage

**SEE Conditions:** SEL, SEGR, SET

#### V. Test Methods

The block diagram, as shown in Figure 1, for the DC-DC Converters contains a power supply for +/- input voltages, an electronic load, a DUT board for the test circuitry and devices, a computer for GPIB control of measurement equipment, and a digital scope to capture any output anomalies, and after the desired voltage input is applied, each of the two device outputs will display on the digital scope, which is set to trigger on voltages that are above or below a predetermined threshold (set to 250 mV). Each device output was tested one after each other.

Table 1, shows the test conditions where tests were conducted for an input nominal voltage of 28V with and without loading and also with worse case conditions of 21V and 35V with 30% loading. Figure 2, shows the test schematic circuit of the SMTR283R3S and Figure 3, shows the internal circuitry of the devices exposed for ion beams at TAMU.

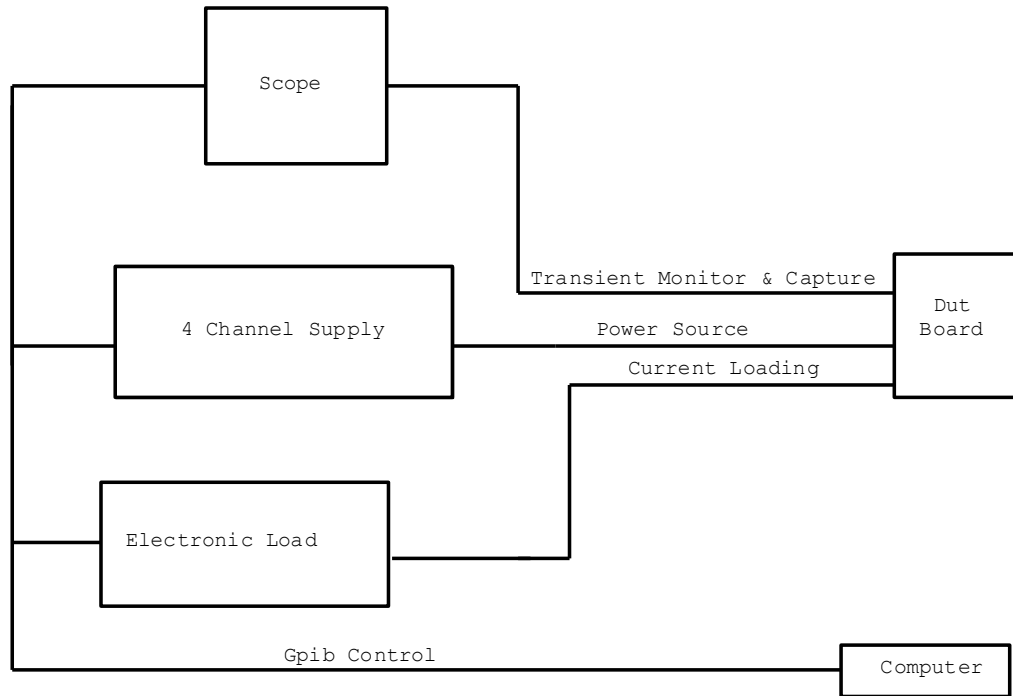

Figure 1. Overall Block Diagram for the testing of the SMTR283R3S

## VI. Test Performance

- Destructive test at high LET ( $>79 \text{ MeVcm}^2/\text{mg}$ ) on 3 parts up to a fluence of  $10^6 \text{ \#/cm}^2$ .
- SET test on 3 parts for at least 2 LET values (starting from lowest LET) for each device output and each condition described in Table 1.

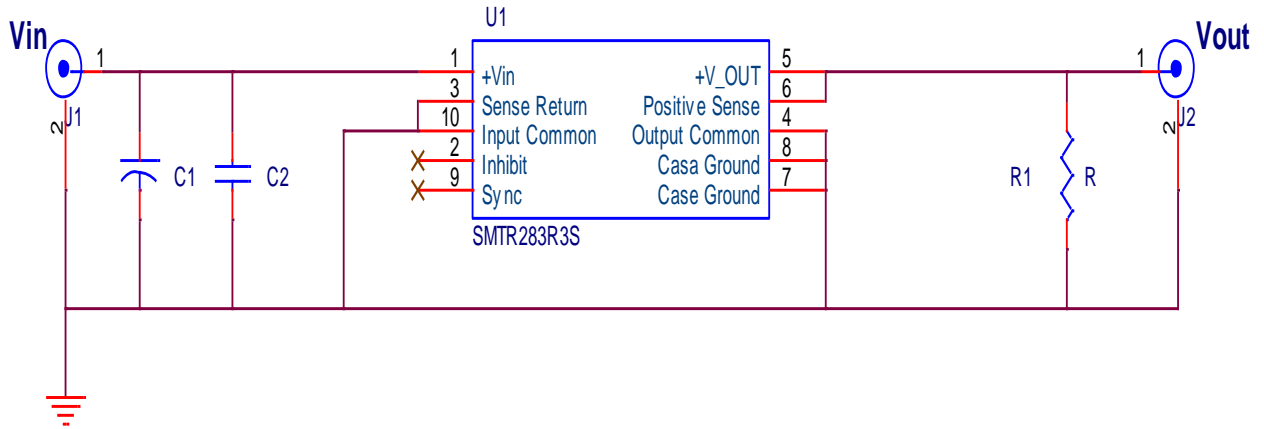

Figure 2. Overall Block Diagram for the testing of the SMTR283R3S

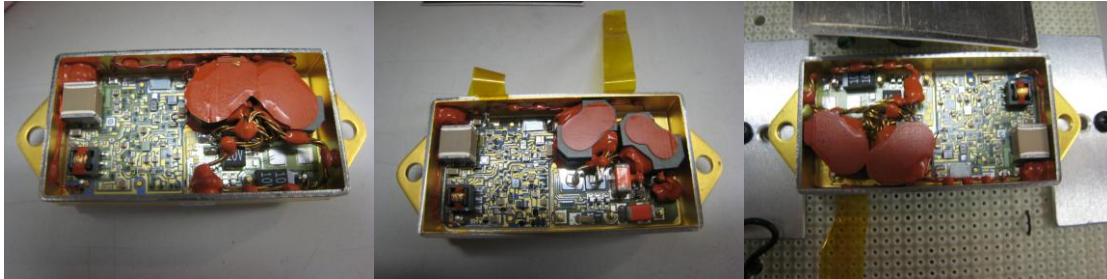

Figure 3. SMTR283R3S internal circuitry exposed for ion beam test at TAMU

## VII. Test Results

Detailed test results are shown in Table 2 below. The devices were exposed from a fluence of  $9.92 \times 10^4$  to  $1.01 \times 10^6$  particles/cm<sup>2</sup> of the Xenon & Tantalum ion beams. Observations for destructive and non-destructive events were for energies up to the maximum LET of 79 MeV-cm<sup>2</sup>/mg at normal angle of incidence. There were no destructive events observed for the SMTR283R3S, but the device was sensitive to SETs and did experience transient events that can be mitigated with using the appropriate LC filtering circuitry in conjunction with this DC-DC converter, with the worse case occurring <700mV peak spikes and <100us for worse case width duration. Charts 1 & 2 show the worse case transients and Chart 3 shows the SET cross sections observed. The tests were run with an input of 28V with no loading and 28V, 21V, & 35V at 30%, loading conditions. In general most SETs were small; therefore this device is suitable for space applications.

It should be noted that for DUT2 SN-0722, DC-0972, no transients were observed. This has impacted the mean curve and further investigation on this particular part is needed to determine the internal makeup of the device to understand why no transients were observed.

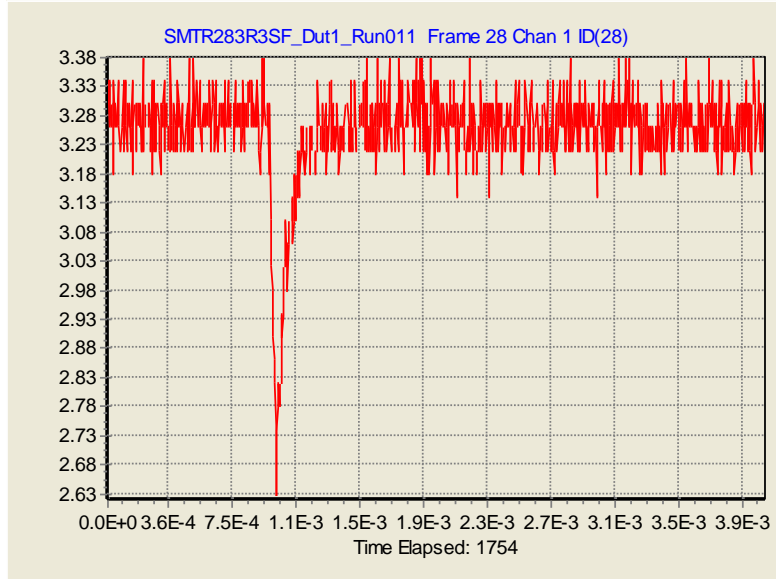

Chart 1. Typical Worst Case Peak Transient < 700mV

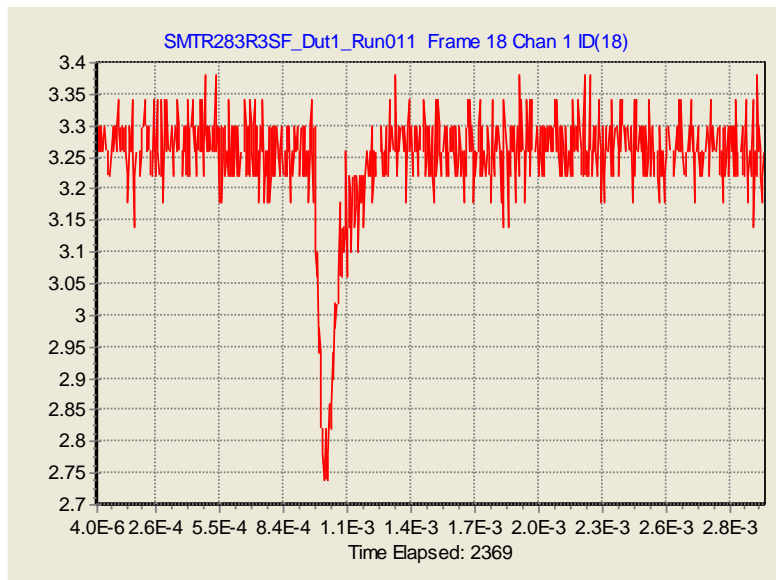

Chart 2. Typical Worst Case Width Transient of < 100us

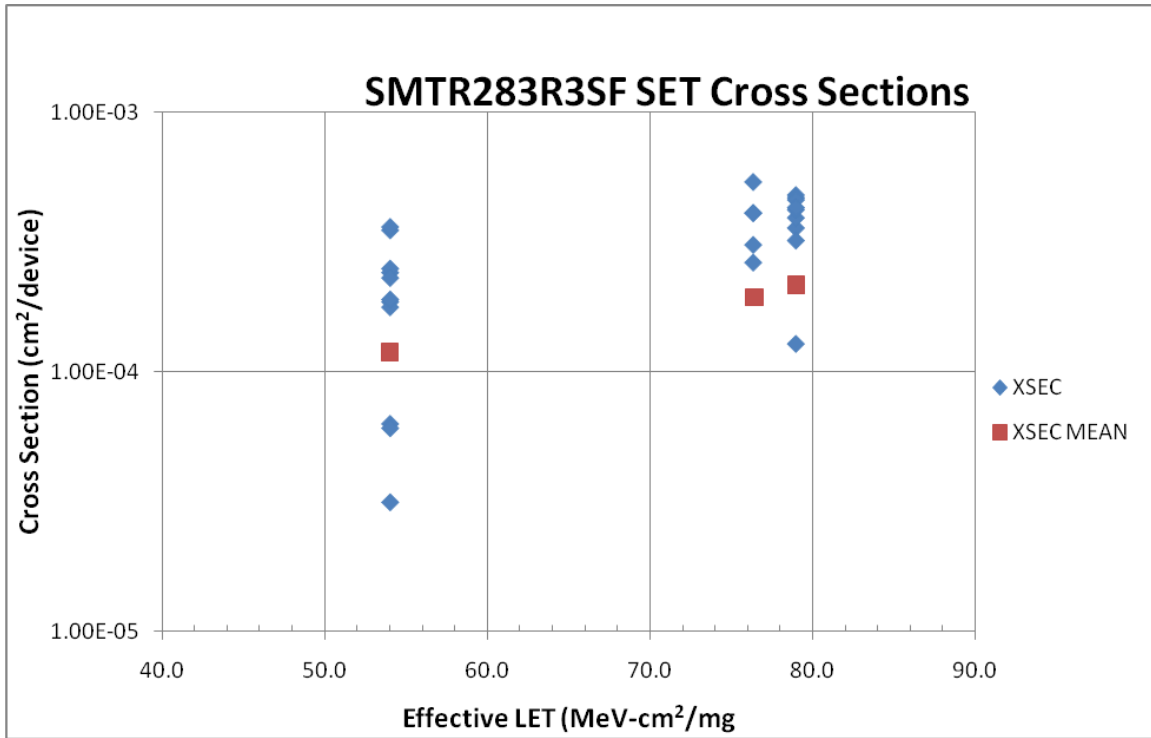

Chart 3. SMTR283R3S SET Cross Sections

Run#	Part #	Serial #	DC	V	Trig	Current(A)	Load(A)	Ion	Energy	LET	LET(ef)	angle	Flux	Fluence <sub>eff</sub>	SET	SEL	σ <sub>SET</sub>
1	SMTR283R3SF	0423	0408	28	3	0.028	0	Xe-15	1366	54	54.0	0	3.91E+04	9.85E+05	0	0	0.00E+00
2	SMTR283R3SF	0423	0408	28	3	0.5	2.73	Xe-15	1366	54	54.0	0	3.94E+04	9.90E+05	31	0	3.13E-05
3	SMTR283R3SF	0423	0408	28	3	0.5	2.73	Xe-15	1366	54	54.0	0	3.82E+04	9.87E+05	62	0	6.28E-05
4	SMTR283R3SF	0423	0408	28	3	0.5	2.73	Xe-15	1366	54	54.0	0	3.81E+04	1.00E+06	186	0	1.86E-04
5	SMTR283R3SF	0423	0408	28	3	0.5	2.73	Xe-15	1366	54	54.0	0	3.80E+04	9.87E+05	175	0	1.77E-04
6	SMTR283R3SF	0423	0408	28	3	0.027	0	Xe-15	1366	54	54.0	0	3.83E+04	1.01E+06	0	0	0.00E+00
7	SMTR283R3SF	0423	0408	28	3	0.027	0	Xe-15	1366	54	76.4	45	3.99E+04	9.87E+05	0	0	0.00E+00
8	SMTR283R3SF	0423	0408	28	3	0.5	2.73	Xe-15	1366	54	76.4	45	3.93E+04	3.56E+05	94	0	2.64E-04
9	SMTR283R3SF	0423	0408	28	3	0.5	2.73	Xe-15	1366	54	76.4	45	1.35E+03	1.00E+05	54	0	5.40E-04
10	SMTR283R3SF	0423	0408	28	3	0.5	2.73	Xe-15	1366	54	76.4	45	1.32E+03	1.30E+05	40	0	3.09E-04
11	SMTR283R3SF	0423	0408	35	3	0.415	2.73	Xe-15	1366	54	76.4	45	1.38E+03	1.00E+05	41	0	4.10E-04
12	SMTR283R3SF	0423	0408	21	3	0.649	2.73	Xe-15	1366	54	76.4	45	1.41E+03	1.00E+05	41	0	4.10E-04
13	SMTR283R3SF	0423	0408	21	3	0.65	2.73	Xe-15	1366	54	54.0	0	1.38E+03	9.96E+04	35	0	3.52E-04
14	SMTR283R3SF	0423	0408	35	3	0.415	2.73	Xe-15	1366	54	54.0	0	1.40E+03	9.95E+04	24	0	2.41E-04
15	SMTR283R3SF	0423	0408	40	3	0.373	2.73	Xe-15	1366	54	54.0	0	1.37E+03	9.94E+04	36	0	3.62E-04
16	SMTR283R3SF	0972	0722	28	3	0.03	0	Xe-15	1366	54	54.0	0	1.42E+03	1.00E+05	0	0	0.00E+00
17	SMTR283R3SF	0972	0722	28	3	0.495	2.73	Xe-15	1366	54	54.0	0	1.37E+03	9.98E+04	0	0	0.00E+00
18	SMTR283R3SF	0972	0722	35	3.1	0.41	2.73	Xe-15	1366	54	54.0	0	1.40E+03	1.00E+05	0	0	0.00E+00
19	SMTR283R3SF	0972	0722	40	3.1	0.369	2.73	Xe-15	1366	54	54.0	0	1.41E+03	1.00E+05	0	0	0.00E+00
20	SMTR283R3SF	0972	0722	21	3.2	0.633	2.73	Xe-15	1366	54	54.0	0	1.43E+03	9.94E+04	0	0	0.00E+00
21	SMTR283R3SF	0972	0722	21	3.1	0.636	2.73	Xe-15	1366	54	76.4	45	1.44E+03	9.98E+04	0	0	0.00E+00
22	SMTR283R3SF	0972	0722	28	3.1	0.493	2.73	Xe-15	1366	54	76.4	45	1.45E+03	9.96E+04	0	0	0.00E+00
23	SMTR283R3SF	0972	0722	35	3.1	0.409	2.73	Xe-15	1366	54	76.4	45	1.47E+03	9.99E+04	0	0	0.00E+00

T030210\_SMTR283R3S

24	SMTR283R3SF	0972	0722	40	3.1	0.369	2.73	Xe-15	1366	54	76.4	45	1.40E+03	1.00E+05	0	0	0.00E+00
25	SMTR283R3SF	0711	0733	28	3	0.51	2.73	Xe-15	1366	54	54.0	0	1.56E+03	9.92E+04	6	0	6.05E-05
26	SMTR283R3SF	0711	0733	35	3	0.422	2.73	Xe-15	1366	54	54.0	0	1.54E+03	1.00E+05	19	0	1.90E-04
27	SMTR283R3SF	0711	0733	40	3	0.378	2.73	Xe-15	1366	54	54.0	0	1.51E+03	1.00E+05	25	0	2.50E-04
28	SMTR283R3SF	0711	0733	21	3	0.657	2.73	Xe-15	1366	54	54.0	0	1.53E+03	9.99E+04	23	0	2.30E-04
29	SMTR283R3SF	0711	0733	28	3	0.029	0	Ta-15	1858	79	79.0	0	2.23E+04	9.90E+05	0	0	0.00E+00
30	SMTR283R3SF	0711	0733	28	3	0.512	2.73	Ta-15	1858	79	79.0	0	2.29E+04	9.61E+05	123	0	1.28E-04
31	SMTR283R3SF	0711	0733	28	3	0.512	2.73	Ta-15	1858	79	79.0	0	1.66E+03	1.48E+05	53	0	3.59E-04
32	SMTR283R3SF	0711	0733	35	3	0.422	2.73	Ta-15	1858	79	79.0	0	1.66E+03	9.93E+04	39	0	3.93E-04
33	SMTR283R3SF	0711	0733	40	3	0.378	2.73	Ta-15	1858	79	79.0	0	1.67E+03	9.97E+04	32	0	3.21E-04
34	SMTR283R3SF	0711	0733	21	3	0.658	2.73	Ta-15	1858	79	79.0	0	1.70E+03	9.98E+04	48	0	4.81E-04
35	SMTR283R3SF	0972	0722	28	3	0.03	0	Ta-15	1858	79	79.0	0	1.76E+03	9.99E+04	0	0	0.00E+00
36	SMTR283R3SF	0972	0722	28	3	0.637	2.73	Ta-15	1858	79	79.0	0	1.66E+03	1.00E+05	0	0	0.00E+00
37	SMTR283R3SF	0972	0722	35	3	0.41	2.73	Ta-15	1858	79	79.0	0	1.69E+03	9.99E+04	0	0	0.00E+00
38	SMTR283R3SF	0972	0722	40	3	0.378	2.73	Ta-15	1858	79	79.0	0	1.60E+03	1.00E+05	0	0	0.00E+00
39	SMTR283R3SF	0972	0722	21	3	0.634	2.73	Ta-15	1858	79	79.0	0	1.55E+03	1.00E+05	0	0	0.00E+00
40	SMTR283R3SF	0423	0408	28	3	0.028	0	Ta-15	1858	79	79.0	0	1.11E+03	1.00E+05	0	0	0.00E+00
41	SMTR283R3SF	0423	0408	28	3	0.505	2.73	Ta-15	1858	79	79.0	0	9.43E+02	9.96E+04	42	0	4.22E-04
42	SMTR283R3SF	0423	0408	35	3	0.416	2.73	Ta-15	1858	79	79.0	0	8.26E+02	1.00E+05	47	0	4.70E-04
43	SMTR283R3SF	0423	0408	40	3	0.372	2.73	Ta-15	1858	79	79.0	0	5.72E+02	9.98E+04	46	0	4.61E-04
44	SMTR283R3SF	0423	0408	21	3	0.648	2.73	Ta-15	1858	79	79.0	0	5.86E+02	1.00E+05	43	0	4.30E-04

Table 2: SMTR283R3S Data Collected at TAMU